

R. N. COOPER.
CALCULATOR.

APPLICATION FILED JUNE 8, 1904.

2 SHEETS—SHEET 1.

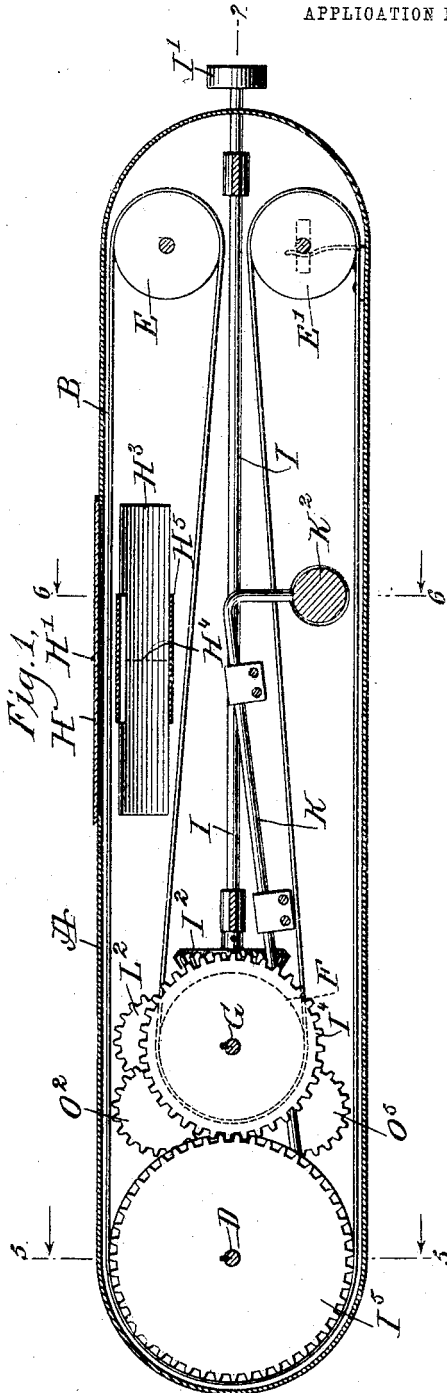
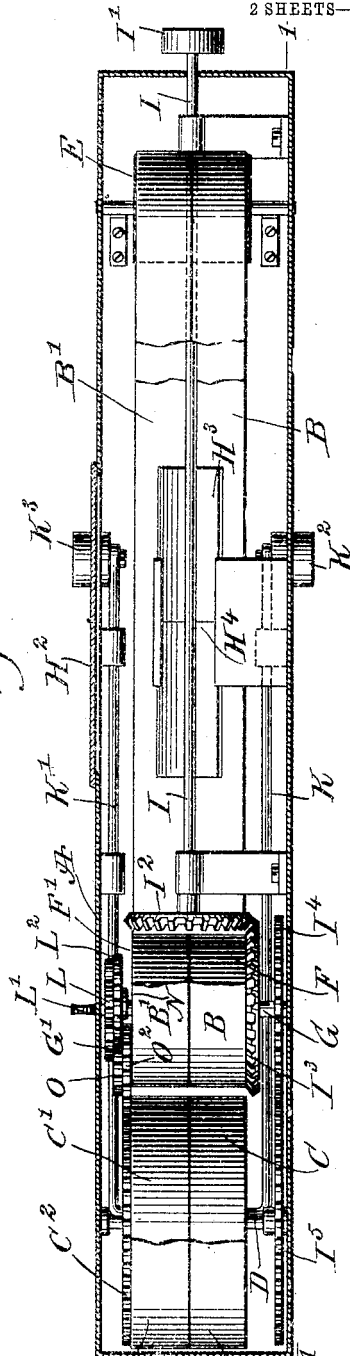

Fig. 1.

Fig. 2.



WITNESSES:

Edward Thorpe
Henry Hooper

INVENTOR
Robert Newton Cooper
BY *Mumford*
ATTORNEYS

R. N. COOPER.
CALCULATOR.

APPLICATION FILED JUNE 3, 1904.

2 SHEETS—SHEET 2.

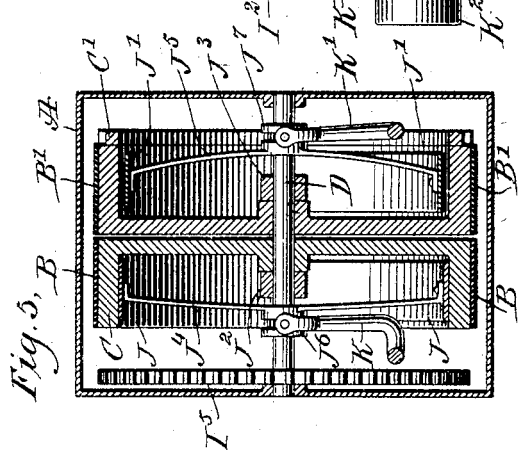
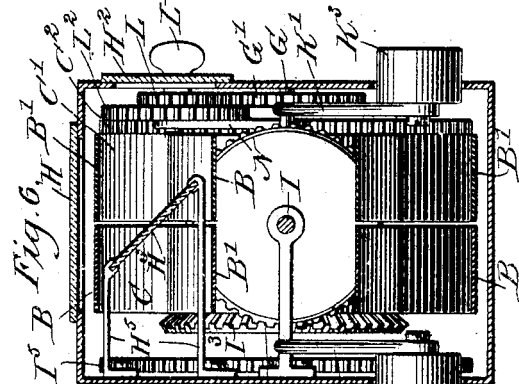
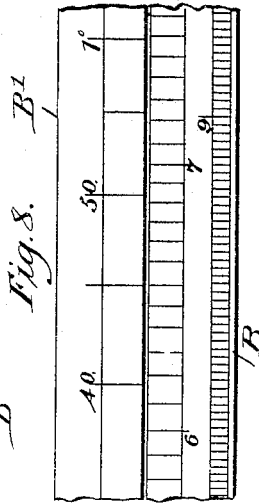
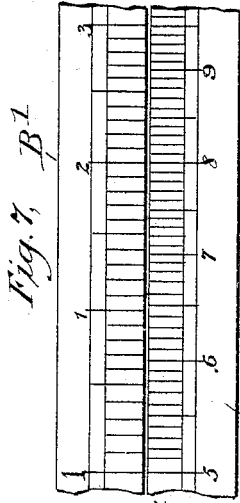
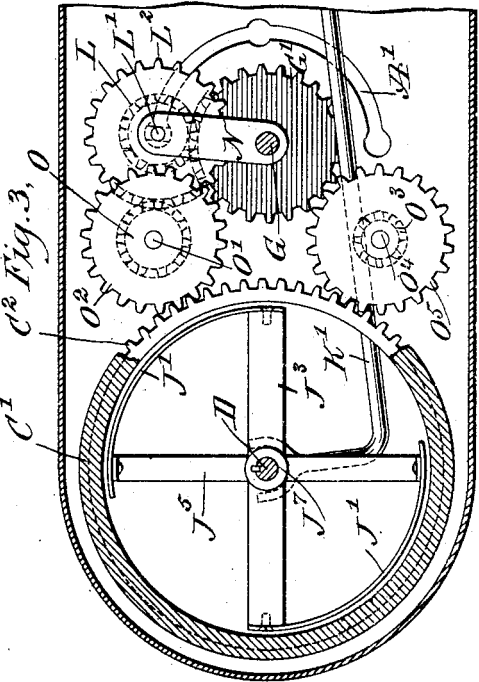
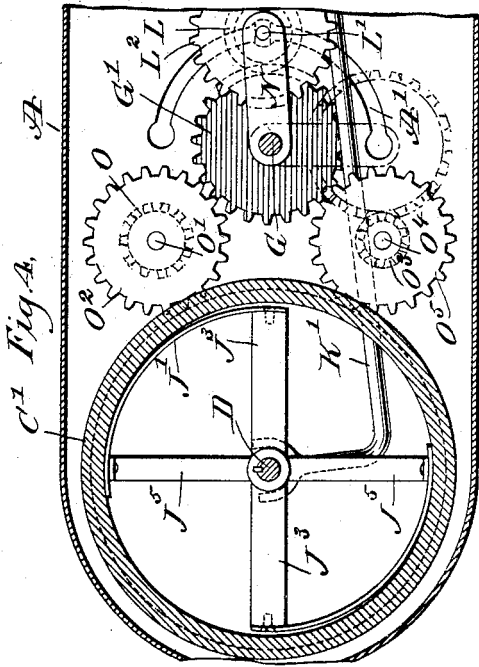

WITNESSES:

Edward Thorpe
Neely Hoskins

INVENTOR
Robert Newton Cooper
BY *Mumford*
ATTORNEYS.

UNITED STATES PATENT OFFICE.

ROBERT NEWTON COOPER, OF SAYBROOK, ILLINOIS.

CALCULATOR.

SPECIFICATION forming part of Letters Patent No. 786,102, dated March 28, 1905.

Application filed June 3, 1904. Serial No. 210,953.

To all whom it may concern:

Be it known that I, ROBERT NEWTON COOPER, a citizen of the United States, and a resident of Saybrook, in the county of McLean and State of Illinois, have invented a new and Improved Calculator, of which the following is a full, clear, and exact description.

The invention relates to registers, and more particularly to slide-rules; and its object is to provide a new and improved calculator designed for obtaining mathematical computations, such as multiplication and division, raising a number to a given power, extracting roots, finding the natural sine or tangent of an angle, and also finding the logarithm of a given number.

The invention consists of novel features and parts and combinations of the same, as will be more fully described hereinafter and then pointed out in the claims.

A practical embodiment of the invention is represented in the accompanying drawings, forming a part of this specification, in which similar characters of reference indicate corresponding parts in all the views.

Figure 1 is a sectional side elevation of the improvement on the line 1 1 of Fig. 2. Fig. 2 is a sectional plan view on the line 2 2 of Fig. 1. Fig. 3 is an enlarged sectional side elevation of part of the improvement, showing the gearing for varying the speed of the scale-tapes. Fig. 4 is a similar view of the same, showing the parts in a different position. Fig. 5 is an enlarged cross-section of the improvement on the line 5 5 of Fig. 1. Fig. 6 is a similar view of the same on the line 6 6 of Fig. 1. Fig. 7 is a plan view of parts of the upper faces of the scale-tapes, and Fig. 8 is a like view of parts of the under faces of the scale-tapes.

Within a suitably-constructed casing A are arranged endless scale-tapes B and B', located one alongside the other and passing over wheels C and C', mounted to rotate loosely on a transverse shaft D, journaled in the sides of the casing A at one end thereof. The tapes B and B' also pass over two idlers E and E', journaled in the other end of the casing A, and the tapes pass from the idlers E E' toward the

wheels C C' to pass around a pair of idlers F F', mounted to rotate loosely on a shaft G, journaled in a suitable bearing arranged on one side of the casing A.

The upper and lower faces of the tapes B and B' are provided with scales, which are practically the same as those now used on the ordinary bar or disk slide-rules, so that further detailed description of the same is not deemed necessary, it being, however, understood that I prefer to provide the upper faces of the tapes B and B' (see Fig. 7) with logarithm-scales. The scales on the under faces of the tapes B and B' (see Fig. 8) are for trigonometric computations, and I prefer to provide the under side of the tape B with two scales, of which one divides the entire length of the tape into five hundred equal divisions to facilitate finding the logarithm of any number, and the other scale on the under face of this tape B is formed of divisions corresponding to different angles to aid in obtaining the tangent of any angle. The under face of the scale B' is provided with a scale the division of which corresponds to different angles to aid in obtaining the natural sine of a given angle.

The upper faces of the scale-tapes B and B' are viewable through a pane H of glass or other transparent material, secured to the top of the casing A and provided with a transversely-extending reading hair-line H'. The under faces of the scale-tapes B and B' are readable through a pane H² of glass or other transparent material attached to one side of the casing A, the scales on the under faces of the tapes being reflected by a mirror H³ through the said pane H², the mirror being set at an angle to the corresponding under faces of the tapes, and the mirror is provided with a reading hair-line H⁴, extending in a transverse vertical plane, also passing through the hair-line H'. The mirror H³ is supported by a suitable bracket H⁵ from one side of the casing, as plainly shown in Fig. 6.

In order to impart a traveling motion to the tapes B and B', the following device is provided: In suitable bearings arranged within the casing A is journaled a longitudinally-ex-

tending shaft I, passing at one end through one end of the casing A, and on the outer end of the shaft is secured a knob or handle I', adapted to be taken hold of by the operator
 5 for turning the shaft I. On the inner end of the shaft I is secured a bevel gear-wheel I² in mesh with a bevel gear-wheel I³, secured on the shaft G, previously mentioned, and on this shaft G is also secured a spur-wheel I⁴ in
 10 mesh with a spur-wheel I⁵, secured to the shaft D. Now when the operator turns the knob or handle I' then the shaft I is rotated, and its rotary motion is transmitted by the bevel gear-wheels I² and I³ to the shaft G, which by the
 15 spur-wheels I⁴ and I⁵ rotates the shaft D.

In order to transmit the rotary motion of the shaft D to either or both wheels C and C', clutch devices are provided preferably consisting of friction-bands J and J', arranged
 20 adjacent to the inner faces of the rims of the wheels C and C', as plainly indicated in Fig. 5. The friction-bands J and J' are mounted at one end on spiders J² and J³, secured on the shaft D, and the other free ends of the
 25 said friction-bands are connected with arms J⁴ and J⁵, mounted to slide transversely on the shaft D and provided with shifting collars K and K', fulcrumed in suitable bearings in the casing A and provided at their free ends
 30 with transversely-extending buttons K² and K³, projecting through suitable apertures in the sides of the casing A to the outside thereof, so as to be within convenient reach of the operator. Normally the resiliency of the friction-bands holds the bands in frictional contact with the inner faces of the rims of the
 35 wheels C and C', so that when the shaft D is turned the friction-bands rotate the wheels C and C' to impart a traveling motion at the same rate of speed to both scale-tapes B and B'.

When it is desired to stop the traveling motion of one of the scale-tapes, then it is only necessary for the operator to press the corresponding button K² or K³, so that the corresponding friction-band J or J' is moved out of
 45 frictional engagement with the corresponding wheel C or C' to prevent the shaft D from rotating the respective wheel. It is understood that when the knob I' is turned and the button K² is pressed then the tape B' is the only one caused to travel, while the other tape, B, remains at a standstill, and when the knob I' is turned and the button K³ is released then the scale-tape B is caused to travel, while the
 50 scale-tape B' remains at a standstill. When both buttons K² and K³ are released and the knob I' is turned, then both tapes B and B' are caused to travel.

In order to vary the traveling speed of the
 60 two tapes B and B', so as to cause the tape B' to travel twice the speed of the tape B or to cause the tape B' to travel three times the speed of the tape B, the following device is provided: On the shaft G is secured a gear-wheel G' in mesh with a pinion L, mounted

to rotate on a stud L', held on the free end of an arm N, fulcrumed loosely on the shaft G. The stud L' extends through a segmental slot A', formed in one side of the casing A, so that the outer end of the stud can be taken hold
 70 of by the operator for swinging the arm N into either an uppermost position, as shown in Fig. 3, a middle position, as shown in Fig. 4, or into a lowermost position, as indicated in dotted lines in Fig. 4. On the pinion L is
 75 secured a gear-wheel L², adapted to mesh with a pinion O at the time the arm N is in an uppermost position, as shown in Fig. 3, the said pinion O being mounted to rotate loosely on a stud O', secured to one side of the casing A.
 80 On the pinion O is fastened a gear-wheel O² in mesh with a gear-wheel C², attached to or forming part of the wheel C'. The pinion L is also adapted to mesh with a pinion O³ at the time the arm N is in a lowermost position, as shown in dotted lines in Fig. 4, and this
 85 pinion O³ is mounted to rotate on a stud O⁴, attached to the side of the casing A, and on the pinion O³ is secured a gear-wheel O⁵ in mesh with the gear-wheel C² on the wheel C'.
 90 The pinions O and O³ are of different diameters, while the gear-wheels O² and O⁵ are alike in size, and consequently when the shaft G is rotated by the operator turning the shaft I, as previously explained, and the arm N is in
 95 an uppermost position, then the gear-wheel G' rotates the pinion L and gear-wheel L², which latter turns the pinion O and gear-wheel O² to rotate the gear-wheel C² and its wheel C' at a rate of speed twice as fast as the wheel C
 100 is rotated directly from the shaft G, as previously explained, by way of the gear-wheels I⁴ and I⁵, and consequently the tape B' travels with twice the speed of the tape B. When the arm N is swung into a lowermost position
 105 and the shaft I is turned, then the rotary motion of the shaft G is transmitted by the gear-wheel G', pinion L, gear-wheel L², pinion O³, gear-wheel O⁵, and gear-wheel C² to the wheel C' to rotate the latter three times as fast as
 110 the wheel C to cause the tape B' to travel three times as fast as the tape B.

By the arrangement described it is evident that the operator by setting the arm N in either an uppermost or lowermost position
 115 can give the desired rate of speed to one tape, so as to cause this tape to travel at a different rate of speed to the other tape, and when it is desired to cause the tapes to travel at the same rate of speed then the operator swings
 120 the arm N into a horizontal position, as shown in Fig. 4, so that the wheels O² and O⁵ are not driven from the shaft G by way of the gear-wheels G' and L² and pinion L; but the wheel C' is driven from the shaft D whenever
 125 the clutch mechanism for the wheel C' is thrown in action to connect the wheel C' with the shaft G.

It is understood that by the arrangement described the tapes can be brought into the
 130

desired relation to each other to permit reading the desired computations on the hair-lines H' and H².

By having the tapes arranged as described they take up very little room within the casing, and the latter need not be of extraordinary length, to permit of conveniently carrying the calculator in a pocket. It will also be seen that by the construction described and shown the tapes and the operating mechanisms for the same are mainly located within the casing, so that the parts are not exposed to moisture, and hence will work easily at all times to permit convenient and easy adjustment of the tapes to quickly bring the tapes to the desired positions.

Having thus described my invention, I claim as new and desire to secure by Letters Patent—

1. A calculator comprising a plurality of endless scale-tapes arranged one alongside the other, and manually-controlled means for imparting a traveling motion to the said tapes at the same or different speeds.

2. A calculator comprising a plurality of endless scale-tapes arranged one alongside the other, and means operated from a common source for imparting a traveling motion to the said tapes at the same or a different speed.

3. A calculator comprising a plurality of endless scale-tapes arranged one alongside the other, manually-controlled means for imparting a traveling motion to the said tapes, and means for holding either of the tapes against movement while the other travels.

4. A calculator comprising endless scale-tapes arranged side by side, means for operating the said tapes at the same or different speeds, and manually-controlled means for stopping the travel of either tape while the other tape is traveling.

5. A calculator comprising endless scale-tapes arranged one alongside the other, and a gearing for imparting a traveling motion to both tapes, provided with means for changing the traveling speed of the tapes, to cause the tapes to travel at the same speed or at a different rate of speed.

6. A calculator comprising endless scale-tapes arranged one alongside the other, and a gearing for imparting a traveling motion to both tapes, provided with means for changing the traveling speed of the tapes, to cause the tapes to travel at a ratio of two to one.

7. A calculator comprising endless scale-tapes arranged one alongside the other, and a gearing for imparting a traveling motion to both tapes, provided with means for changing the traveling speed of the tapes, to cause the tapes to travel at a ratio of three to one.

8. A calculator comprising a casing having a viewing-pane in the top and a like pane in the side, endless scale-tapes arranged one alongside the other and mounted to travel in the said casing, the upper faces of the tapes being

viewable at the top viewing-pane, and a mirror in the casing for reflecting the under faces of the scale-tapes through the side pane. 65

9. A calculator comprising a casing having a viewing-pane in the top and a like pane in the side, endless scale-tapes arranged one alongside the other and mounted to travel in the said casing, the upper faces of the tapes being viewable at the top viewing-pane, a mirror in the casing for reflecting the under faces of the scale-tapes through the side pane, and means for imparting a traveling motion to the said tapes at the same or at a different speed, the said means being arranged within the casing and having manually-controlled parts extending to the outside of the casing for actuating the said means. 70 75 80

10. A calculator comprising a casing having a viewing-pane in the top and a like pane in the side, endless scale-tapes arranged one alongside the other and mounted to travel in the said casing, the upper faces of the tapes being viewable at the top viewing-pane, a mirror in the casing for reflecting the under faces of the scale-tapes through the side pane, means for imparting a traveling motion to the said tapes at the same or at a different speed, the said means being arranged within the casing and having manually-controlled parts extending to the outside of the casing for actuating the said means, and manually-controlled means within the casing and extending to the outside thereof to be within convenient reach of the operator, for stopping one of the tapes while the other is traveling. 85 90 95

11. A calculator comprising a casing having a viewing-pane in the top and a like pane in the side, endless scale-tapes arranged one alongside the other and mounted to travel in the said casing, the upper faces of the tapes being viewable at the top viewing-pane, a mirror in the casing for reflecting the under faces of the scale-tapes through the side pane, means for imparting a traveling motion to the said tapes at the same or at a different speed, the said means being arranged within the casing and having manually-controlled parts extending to the outside of the casing for actuating the said means, and manually-controlled means within the casing and having parts extending to the outside thereof to allow of varying the speed of the tapes. 100 105 110 115

12. A calculator comprising a casing having a viewing-pane provided with a reading hair-line, endless scale-tapes arranged one alongside the other and mounted to travel in the said casing, and a mirror in the casing, to reflect the scales on the tapes through the said pane. 120

13. In a calculator, endless scale-tapes, wheels around which the tapes pass, a driven shaft, means for operating the said wheels from said shaft, pinions arranged one above the other and geared with the tape-carrying 125

wheels, and a swinging pinion geared with the driven shaft and carrying a gear-wheel adapted to mesh with either of the first-named pinions.

14. In a calculator, endless scale - tapes,
5 wheels around which the tapes pass, one of the
wheels carrying a gear-wheel, a driven shaft,
means for operating the wheels from the
driven shaft, pinions arranged one above the
other and each carrying a gear-wheel meshing
10 with the gear-wheel of the tape-carrying
wheel, an arm mounted to swing on the driven
shaft, a pinion mounted in the said arm and
carrying a gear-wheel adapted to mesh with
15 either of the first-named pinions, and a gear-
wheel on the driven shaft and meshing with
the pinion on the swinging arm.

15. In a calculator, endless scale - tapes,
wheels around which the tapes pass, means
for operating the said wheels, spiders secured
to the axis of the wheel, arms mounted to slide 20
on the said axis, friction-bands having one end
secured to the spiders and the other ends to
the arms, said bands being adapted to engage
the inner faces of the wheels, and operating-
rods connected with the said sliding arms. 25

In testimony whereof I have signed my name
to this specification in the presence of two sub-
scribing witnesses.

ROBERT NEWTON COOPER.

Witnesses:

ROBERT O. WILLS,
N. B. WEBSTER.